



## Acceptance and delivery terms Herfa-Neurode Underground Waste Disposal Plant (Last revised: 1<sup>st</sup> November 2023)

### Exclusion criteria

#### The following waste may not be deposited:

- radioactive waste
- liquid waste (also such waste that contains free liquids or releases them only after a longer period of standing or through vibrations)
- infectious waste as well as body parts and organs
- unidentified or new chemical waste from research, development, and training activities, the effects of which on man and the environment are unknown
- whole or split used tyres
- Waste that causes considerable odour pollution
- biodegradable (organic) waste
- Waste that, under deposit conditions (30°C), leads to an increase in volume through reactions with itself or with the rock, the formation of spontaneously flammable, toxic (> 10x MAC) or explosive substances or gases (gases > 10 % LEL<sup>1</sup>), or other hazardous reactions
- Waste that is explosive, highly or highly flammable under deposit conditions (30° C), releases a pungent odour, or is not sufficiently stable with respect to geomechanical conditions.

---

### Information on the verification/notification procedure

- **The underground depository (UD) may accept waste from Germany in a privileged procedure in accordance with the Ordinance on Waste Recovery and Disposal Records. Waste producers or their authorised representatives can therefore submit the necessary documents directly to the UD.<sup>2</sup>**
- If applicable, an obligation to tender delivery must be observed.
- Notification is required for waste not originating in Germany.
- Please contact us regarding the documents to be submitted.
- The declaration of acceptance of the UD is based on the waste declaration submitted by the waste producer as well as the analysis results determined based on a representative sample of the waste.
- **Waste-specific special regulations are laid down on a binding basis as part of the verification/notification procedure.**
- If the type, quantity, and origin of the waste changes significantly compared with the information in the declaration, the UD must be informed immediately of this fact in writing

---

<sup>1</sup> LEL: Lower explosion limit

<sup>2</sup> Cover sheet proof of disposal, responsible declaration, declaration analysis, protocols on sampling and sample preparation and supplementary sheet UD



## Required accompanying documents

- The required accompanying documents depend on the type and origin of the waste as well as on legal requirements. **They must be completed in full and presented at the time of acceptance. Otherwise, we are entitled to reject the delivery.**
- For deliveries from Germany: accompanying certificates<sup>3</sup>, written instructions, and weighing card as well as the ADR certificate for dangerous goods.
- In the case of deliveries from abroad, the consignment note and dispatch/accompanying form are also included.
- **In addition to the legal requirements, the accompanying documents must indicate the type and number of containers as well as the K+S code.**
- If the weighing card is missing, a weighing will be carried out on acceptance. Random control weighing is carried out on all deliveries.

## Waste packaging

- **In principle, waste must be packed.** Exceptions are deliveries in silo lorries (if the packaging in the UD is done in Big Bags) as well as large devices/containers that cannot be packed (by arrangement).
- **The type of packaging** (sheet steel drums, sheet steel boxes, Big Bags) depends on the waste characteristics and **is bindingly determined within the framework of the verification/notification procedure.**
- Details of the packaging types can be found on the following pages.
- **Each container must be clearly and permanently labelled with the K+S Code** (character height at least 10 cm; not on the lid; no paper labels).
- For dangerous goods, the packaging must meet the ADR requirements and be labelled in accordance with GefStoffV [Ordinance on Hazardous Substances] or Directive 67/548/EEC.
- **The containers must be undamaged and externally clean.**
- When delivered in silo lorries, the temperature of the waste must not exceed 80°C.

---

## Delivery of waste

### Opening hours of the underground depository:

Monday to Friday 5:30 a.m. to 1:00 p.m.  
(packaged material)

### Delivery in silo lorry:

Monday 5:30 a.m. to 11:59 p.m.  
Tuesday to Friday 12:01 a.m. to 11:59 p.m.

In your own interest, we kindly ask you to notify us in writing of the deliveries in advance.

**Please arrange delivery dates with the UD in good time email, fax, or telephone:**

**E-Mail: [dispo\\_utdhn@k-plus-s.com](mailto:dispo_utdhn@k-plus-s.com)**

**Telephone: +49 (6624) 81-1308**

**Fax: +49 (6624)81- 1358**

---

<sup>3</sup> Accompanying certificates must be kept electronically in accordance with the Ordinance on Waste Recovery and Disposal Records.



### Lorry delivery:

- Lorries with containers must be unloadable from the passenger side.
  - The StVO (Highway Code) applies on the factory premises, max. 30 km/h.
  - If necessary, instruction by Human Resources.
  - Personal protective equipment such as safety shoes, helmet, and safety goggles, must be carried on the vehicle and worn when entering the plant premises. Mask and gloves must also be carried and worn if necessary.
- 

### Acceptance of waste at the UD

- An acceptance control is carried out for each waste delivery; during the inspection the identity of the waste is checked (clearance in approx. 30 minutes) The UD assumes no liability for compliance with this time specification.
- **Waste that does not comply with the declaration in the proof of disposal or notification or which is inadequately packed can be rejected.**
- The UD does not accept any liability for damage that occurs during unloading of the lorries or wagons – for example, because of the following:
  - incorrectly loaded or slipped pallets/loads,
  - pallets not complying with UD terms
  - an additional load that has not been reported to the unloading personnel.

## Drum made of sheet steel drums

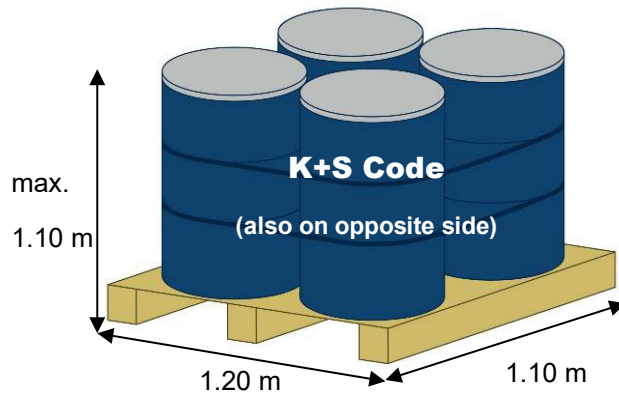

**Pallet and drums must be undamaged and clean on the outside; the drums must be tightly closed.**

<p><b>Drum container</b></p> <ul style="list-style-type: none"> <li>- Sheet steel drums are accepted only as drum containers</li> <li>- A drum container usually consists of 4 sheet steel drums of equal height, standing on a pallet</li> <li>- Total height the container: max. 1.10 m</li> </ul>	<p><b>Identification</b></p> <ul style="list-style-type: none"> <li>- permanent inscription with 'K+S Code' (no stickers)</li> <li>- on every drum</li> <li>- Character height at least 10 cm</li> <li>- visible on the sides that the forklift lorry picks up (not on the cover)</li> <li>- labelling according to ADR and the Ordinance on Hazardous Substances if necessary</li> </ul>
<p><b>Securing the container</b></p> <ul style="list-style-type: none"> <li>- 2 steel bands (other bands on request)</li> <li>- each with a width of at least 25 mm</li> </ul>	<p><b>Drums</b></p> <ul style="list-style-type: none"> <li>- 4 sheet steel drums of approx. 200 litres</li> <li>- for dangerous goods, type approved according to ADR</li> <li>- with PE liner (0.2 mm thick), tightly sealed (exceptions possible for hot-filled waste)</li> </ul>
<p><b>UD pallet</b></p> <ul style="list-style-type: none"> <li>- Width: 1.20 m; depth: 1.10 m</li> <li>- 1.20 m wide side; can be picked up with a forklift</li> <li>- closed planking</li> </ul>	<p><b>Cover</b></p> <ul style="list-style-type: none"> <li>- removable</li> <li>- outward pointing clamping ring closure with safety cotter pin</li> <li>- permissible gross mass per drum must not be exceeded</li> </ul>

## Big Bags (IBC-F)

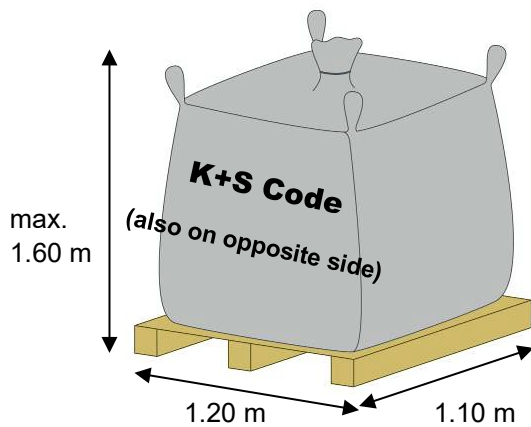

**Pallet and Big Bag must be undamaged and clean on the outside; the Big Bag must be tightly closed.**

<p><b>Big Bag design</b></p> <ul style="list-style-type: none"> <li>- 4 lifting loops in the corners</li> <li>- closed bottom shape (no bottom opening)</li> <li>- demonstrably approved for underground use: flame retardant, antistatic, harmless to mining hygiene</li> <li>- dust-tight (e.g. with seam sealing)</li> <li>- if necessary, two-layer fabric</li> <li>- Specifications on the type of construction are made within the framework of the verification/notification procedure</li> </ul>	<p><b>Identification</b></p> <ul style="list-style-type: none"> <li>- permanent inscription with 'K+S Code' (no stickers) on opposite sides</li> <li>- Character height at least 10 cm</li> <li>- visible on the sides that the forklift lorry picks up</li> <li>- labelling according to ADR and the Ordinance on Hazardous Substances if necessary</li> </ul>
<p><b>Big Bag filling</b></p> <ul style="list-style-type: none"> <li>- Filling without protrusion over the pallet base dimensions</li> <li>- only for bulk material without pointed, sharp-edged, or coarse particles</li> <li>- Gross weight according to approval but max. 1,500 kg</li> <li>- Total height including top skirt: max. 1.60 m (Big Bag + pallet + top skirt)</li> <li>- Filled Big Bags must be dimensionally stable and stackable</li> </ul>	<p><b>UD pallet</b></p> <ul style="list-style-type: none"> <li>- Width: 1.20 m; depth: 1.10 m</li> <li>- 1.20 m wide side; can be picked up with a forklift</li> <li>- closed planking</li> </ul>

## Sheet steel crate (IBC)

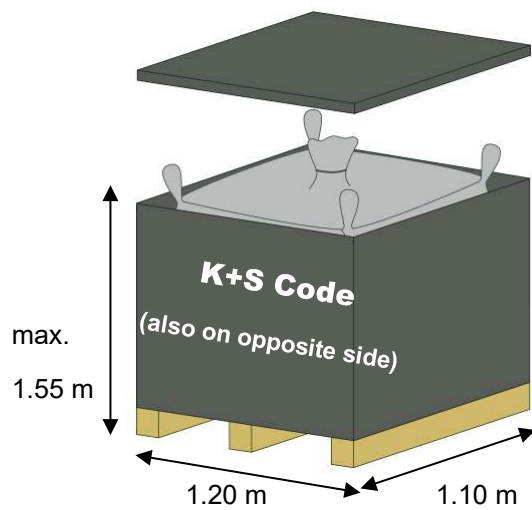

**Box and base must be undamaged and clean on the outside; the box must be tightly closed.**

<p><b>Execution and filling</b></p> <ul style="list-style-type: none"> <li>- closed sheet steel box with internal PE liner or Big Bag</li> <li>- Sheet thickness (base + hooded lid) <math>\geq</math> 1.25 mm</li> <li>- Material St37</li> <li>- Gross weight according to approval; max. 3,000 kg</li> <li>- Cover screwed</li> </ul>	<p><b>Identification</b></p> <ul style="list-style-type: none"> <li>- permanent inscription with 'K+S Code' (no stickers) on opposite sides</li> <li>- Character height at least 10 cm</li> <li>- visible on the sides that the forklift lorry picks up</li> <li>- labelling according to ADR and the Ordinance on Hazardous Substances if necessary</li> </ul>
<p><b>Measurements</b></p> <ul style="list-style-type: none"> <li>- Width: 1.20 m; depth: 1.10 m</li> <li>- Total height (box and base): max. 1.55 m</li> <li>- other dimensions on request (max. length: 2.20 m)</li> </ul>	<p><b>Crate underlay</b></p> <ul style="list-style-type: none"> <li>- nailed on UD pallet or feet made of squared timber or sectional steel</li> <li>- 1.20 m wide side; can be picked up with a forklift</li> </ul>

## Pallet for waste delivery

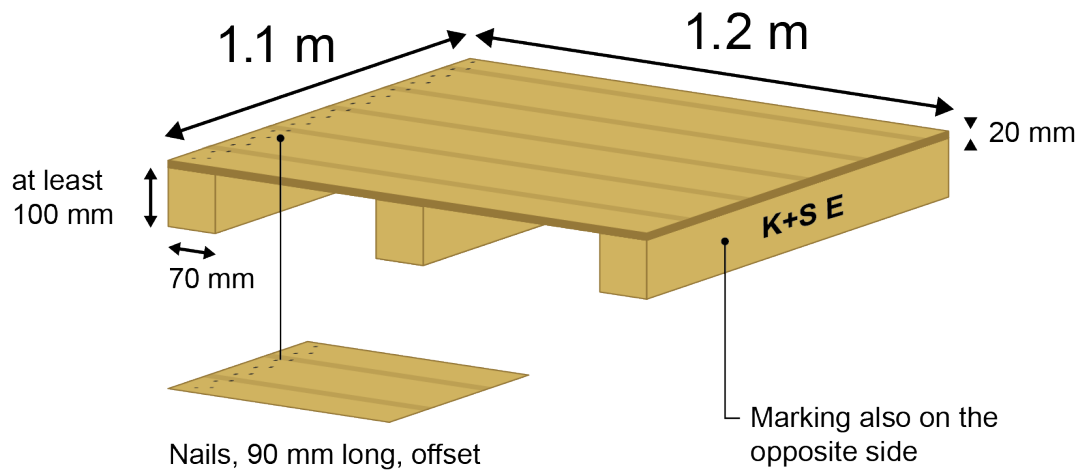

### Specifications

- load capacity of the pallet: approx. 1500 kg
- pallet dimensions: 1.1 m x 1.2 m
- nails: 90 mm long, offset
- number of squared timbers: 3
- height (squared timber): at least 100 mm
- width (squared timber): 70 mm
- length (squared timber): 1.1 m
- cover sheets: 20 mm high, without any gaps over the entire surface

### Important:

Pallet must be able to be picked up by forklift from the 1.2 m wide side and stacked at least four times. The pallet must also have a K+S E marking on both sides.